

# EFHIPS

## PKE Alarm with Remote & Engine Push Start Security System

### INSTALLATION MANUAL



Professional Installation Required

Smartphone APP: NENGKEE

This system is designed for professional installation. Read this manual completely before installation. Incorrect installation may cause damage to the vehicle or the system.

- Disconnect the negative battery cable before installation.
- Use a digital multimeter to verify each circuit.
- Never use wire color alone to identify vehicle circuits.
- Never work on the system while the vehicle battery is connected.
- If the vehicle uses a factory immobilizer or chip key, a bypass solution may be required.
- Test every function before reinstalling panels.

### **WARNING**

Never connect the starter wire directly to the starter motor. Always verify the correct ignition switch starter wire and follow the vehicle-specific wiring method.

# PACKAGE CONTENTS



Product kit overview

No.	Item	Qty
1	Control Module	1
2	Main Wiring Harness	1
3	6-Pin High Current Harness	1
4	Push Start Button	1
5	Remote Controls	2
6	PKE Antennas	2
7	LED Indicator	1
8	Buzzer	1
9	Shock Sensor	1
10	User Manual	1

## Before You Start

Check all parts before installation. If any item is missing, contact EFHIPS support before cutting or connecting vehicle wires.

# SYSTEM OVERVIEW

Signal flow: authorized input -> control module -> vehicle output circuits.

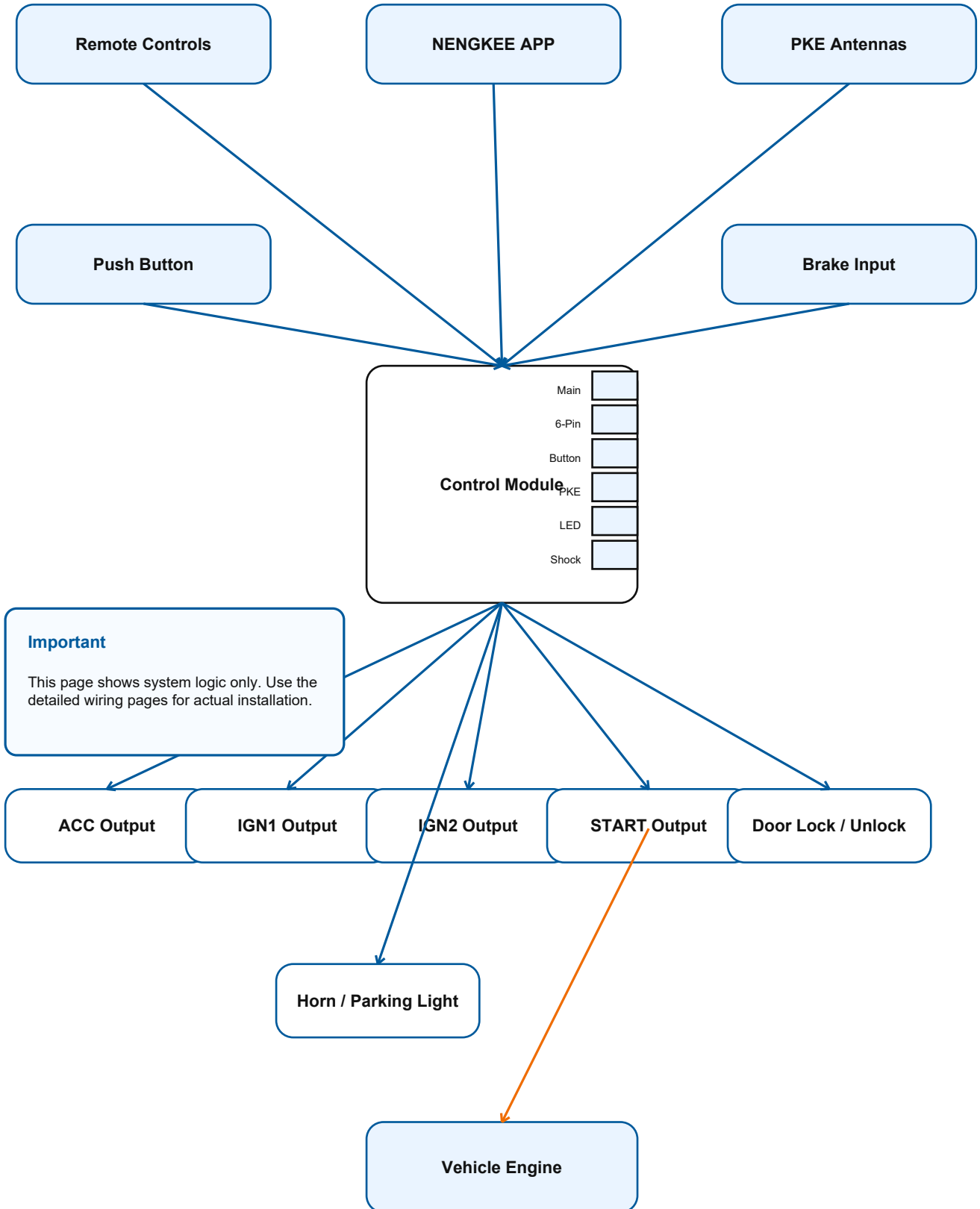

# CONTROL MODULE



Control module connector side



Control module front

Label	Port / Area	Function
A	Main Harness	Low-current signal connections
B	6-Pin High Current	ACC / IGN / START circuits
C	Push Button / Program	Button and learning functions
D	PKE / Antenna Port	Passive keyless antenna input
E	LED / Buzzer Port	Status and sound output
F	Shock Sensor Port	Security trigger input

## Mounting Guidance

Install the module under the dashboard, away from HVAC ducts, water, sharp edges and moving pedals. Secure with cable ties after all tests pass.

# MAIN WIRING HARNESS (18 PIN)

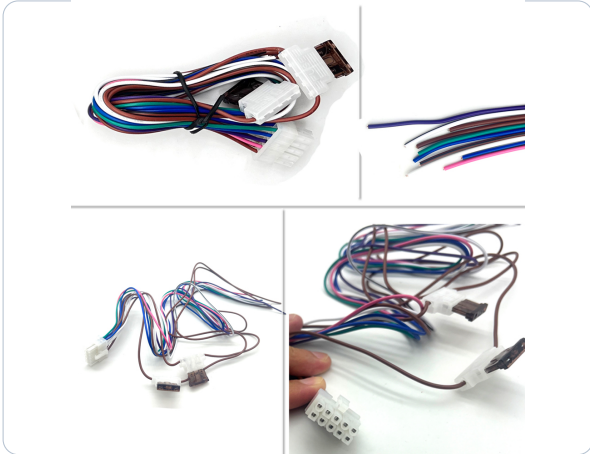

Main wiring harness

## Installer Rule

The table follows the supplied manual wiring logic. Always verify the actual harness revision and vehicle circuit with a multimeter before connecting.

Pin	Wire Color	Function	Description
1	Black	Ground	Connect to vehicle chassis ground
2	Red	+12V Constant	12V power input where specified
3	Green	Brake Input	Connect to brake switch +12V output
4	Blue	ACC Input / Output	Accessory signal as required
5	White	IGN1 Output	12V output when IGN ON
6	Brown	IGN2 Output	12V output when IGN2 ON
7	Yellow	START Output	12V output when START/cranking
8	Orange	Parking Light Output	Parking light flash output
9	Gray/Black	Lock Output (-)	Negative lock output
10	Gray	Unlock Output (-)	Negative unlock output
11	Purple	Trunk Output (-)	Negative trunk output
12	Pink	Horn Output (-)	Negative horn output
13	Blue/White	Door Trigger Input	Door trigger signal input
14	White/Black	Foot Brake Input	Brake signal input
15	Brown/White	Hood Input	Hood pin switch input
16	Black/White	Oil Pump / Fuel	Fuel pump / oil signal if required
17	Green/White	Hand Brake Input	Parking brake input
18	Yellow/Black	Neutral Input	Neutral safety input

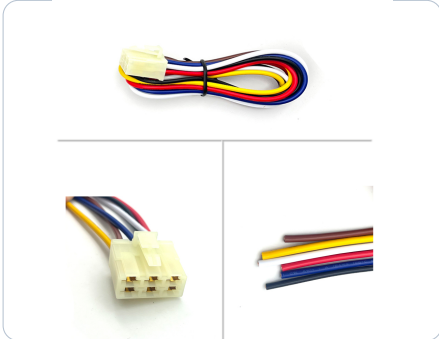

# 6-PIN HIGH CURRENT CONNECTOR

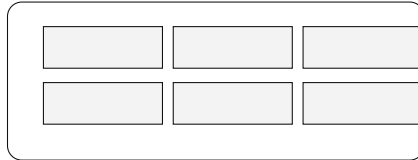

6-pin high current harness

6-PIN HIGH CURRENT CONNECTOR



<b>RED</b>	+12V Battery Input		Constant battery power, use fuse
<b>BLACK</b>	Ground		Vehicle chassis ground
<b>BLUE</b>	ACC Output		Accessory circuit
<b>WHITE</b>	IGN1 Output		Ignition 1 circuit
<b>BROWN</b>	IGN2 Output		Ignition 2 / heater control
<b>YELLOW</b>	Starter Output		Starter solenoid signal

## WARNING

All outputs are 12V positive. Use correct fuse protection. Do not connect the starter output wire directly to the starter motor. Connect to the factory starter signal wire at the ignition switch harness.

## Output Behavior

ACC powers accessory circuits. IGN1/IGN2 power engine and vehicle circuits. START is active only during cranking.

# IGNITION SWITCH WIRING GUIDE

Circuit	Voltage Test
BAT +12V	Always +12V
ACC	+12V in ACC / ON
IGN1	+12V in ON / START
IGN2	+12V in ON, vehicle dependent during START
START	+12V only while cranking

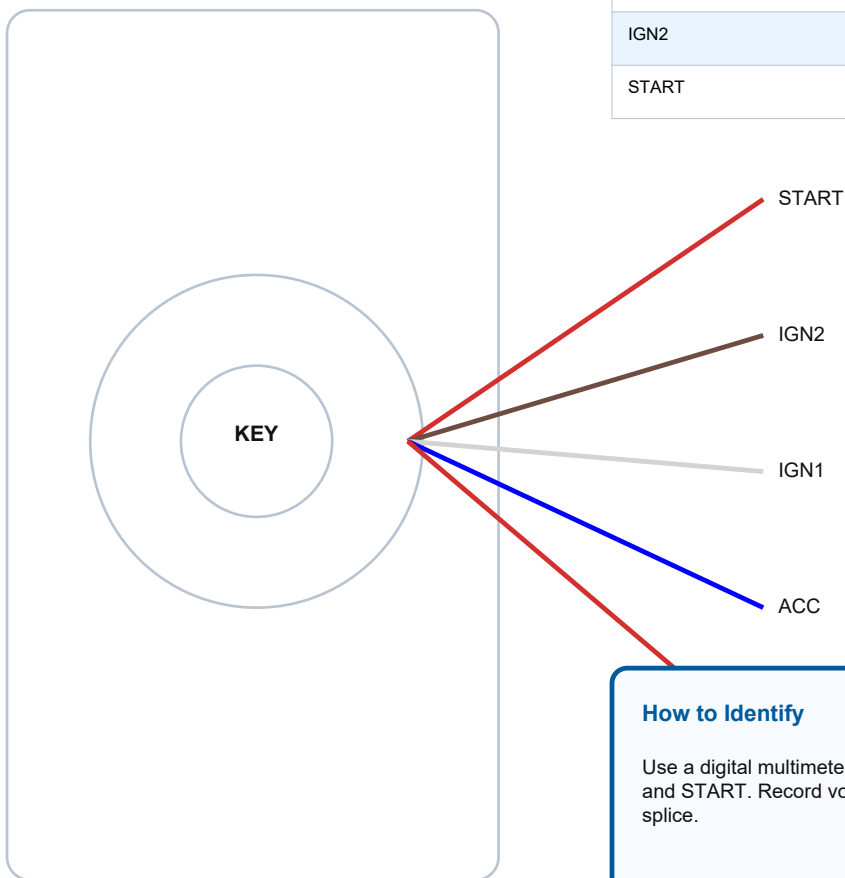

## How to Identify

Use a digital multimeter. Turn the key through OFF, ACC, ON and START. Record voltage behavior before making any cut or splice.

## WARNING

Chip-key or immobilizer vehicles may require a bypass module. The push start system cannot bypass all factory immobilizers by itself.

# DOOR LOCK WIRING - NEGATIVE TRIGGER

Factory lock / unlock uses negative signal.

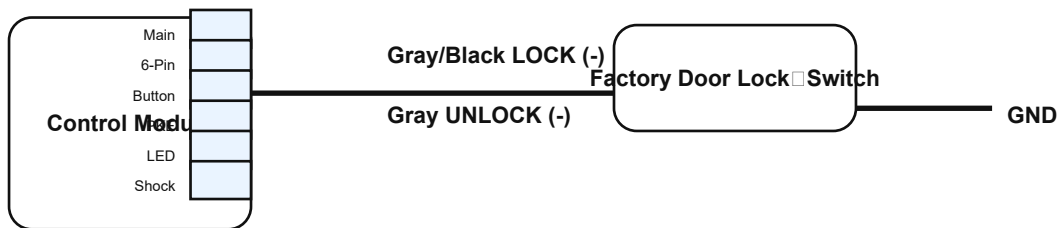

Signal	EFHIPS Wire	Connect To
LOCK	Gray/Black (-)	Factory lock switch wire
UNLOCK	Gray (-)	Factory unlock switch wire
Common	Ground	Vehicle chassis ground

## Test

When the correct wire is briefly grounded, the factory lock or unlock action should occur. If not, do not connect until the lock type is confirmed.

# DOOR LOCK WIRING - POSITIVE TRIGGER

Factory lock / unlock requires positive +12V signal. Use relay conversion.

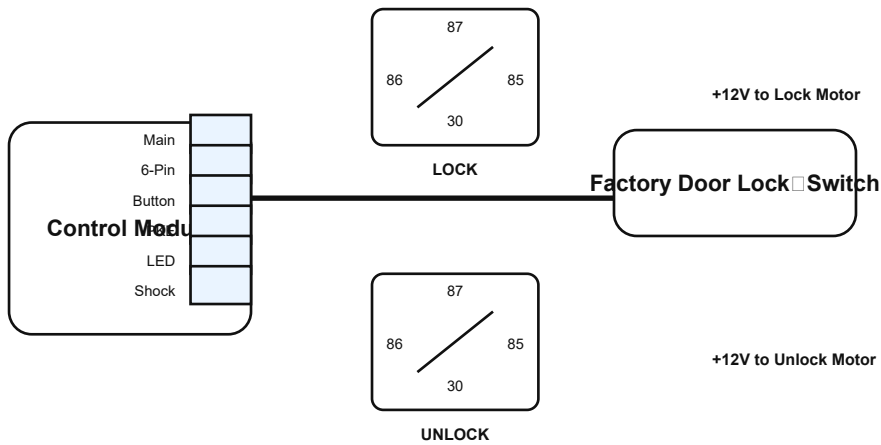

Relay Pin	Connection
85	EFHIPS negative lock/unlock output
86	+12V
30	+12V fused input
87	Factory lock or unlock wire

## WARNING

Do not connect a negative output directly to a positive-trigger lock wire. Use relays as shown.

# DOOR LOCK WIRING - REVERSE POLARITY

Factory system reverses motor polarity. Relays are required.

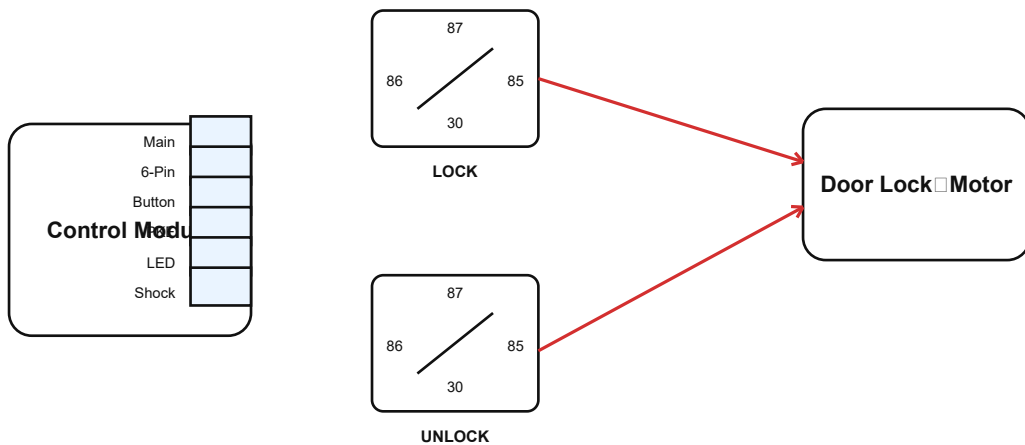

## Installer Note

Reverse polarity systems require cutting the factory motor wires and inserting relay contacts correctly. If wired incorrectly, the lock motor may not move or may blow a fuse.

## WARNING

Confirm motor side and switch side before cutting factory wires.

# DOOR LOCK WIRING - VACUUM SYSTEM

Vacuum pump type central locking.

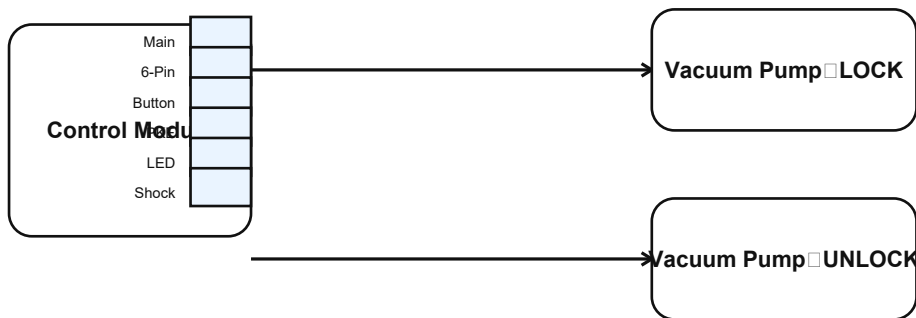

Action	Control
LOCK	Pulse vacuum pump lock wire
UNLOCK	Pulse vacuum pump unlock wire

### Compatibility

Some older European vehicles use vacuum locking. Confirm pump control method before connecting.



# PUSH START BUTTON WIRING

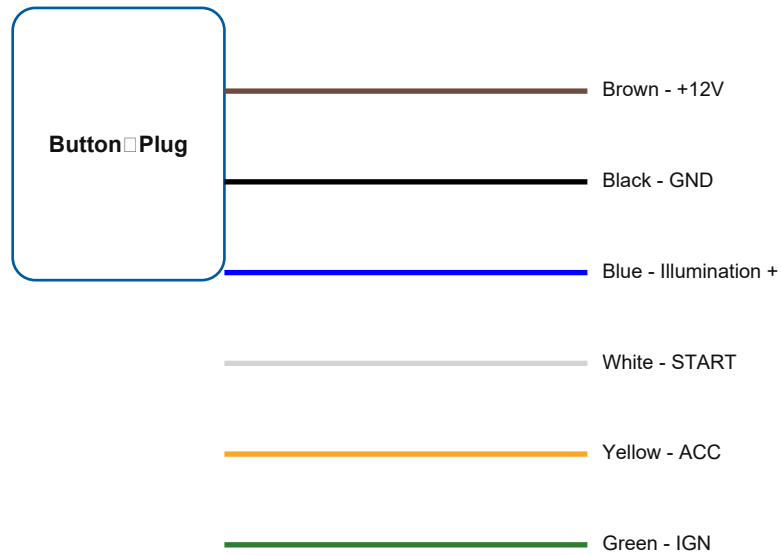

Button Action	System Response
Press once without brake	ACC ON
Press twice without brake	IGN ON
Press brake + button	Engine START
Press when engine running	Engine STOP



LED indicator

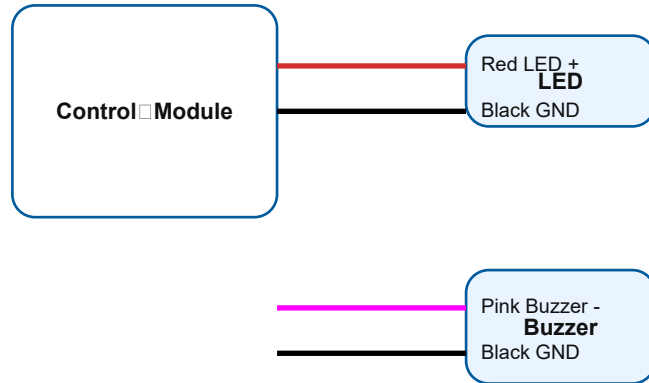

- Install LED where visible to the driver.
- Install buzzer under dashboard, not sealed behind thick trim.
- Confirm LED flashes during programming mode.

# SHOCK SENSOR WIRING

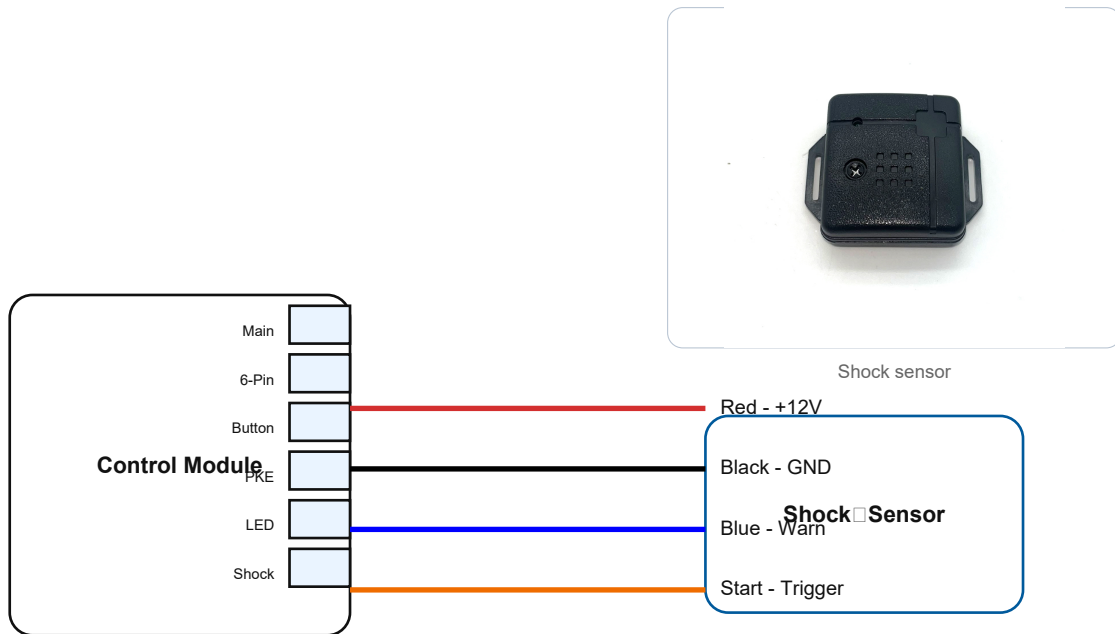

## Adjustment

Mount the sensor firmly to the vehicle body or solid harness area. Adjust sensitivity after installation. Too high sensitivity may cause false alarms.

# REMOTE PROGRAMMING



Remote controls

**1. Turn ignition ON.**

**2. Press and hold the programming button on the control module for 5 seconds.**

**3. LED will flash.**

**4. Press any button on the remote.**

**5. Buzzer sounds once to confirm programming.**

**6. Repeat for next remote, maximum 4 remotes.**

## Note

If no operation is made within 10 seconds, the system exits programming mode automatically.

## FUNCTION SETTING (DIP SWITCH)

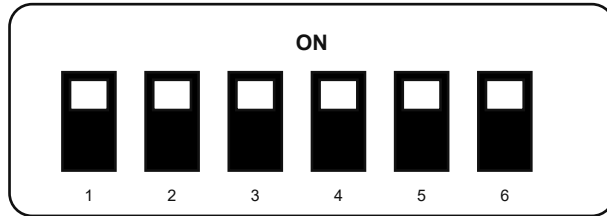

No.	Function	OFF	ON
1	Auto Lock	Disable	Enable
2	Auto Unlock	Disable	Enable
3	Remote Start	Disable	Enable
4	PKE	Disable	Enable
5	Horn Chirp	Disable	Enable
6	Starter Cut	Disable	Enable

# REMOTE START WIRING DIAGRAM

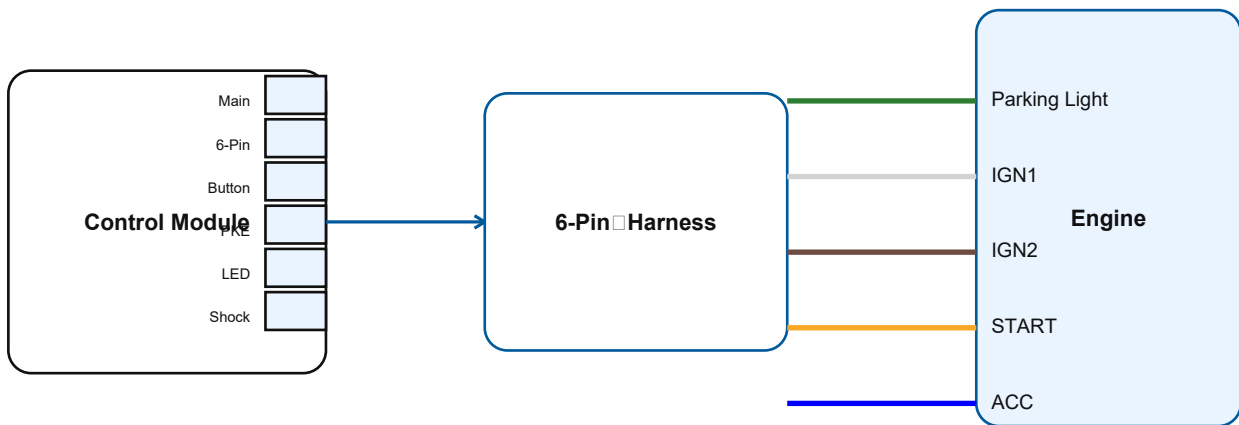

## Remote Start Conditions

Remote start requires correct brake, hood, hand brake/neutral safety and ignition wiring. Some vehicles require immobilizer bypass for remote start to continue running.

## REMOTE START SAFETY CHECK

- Foot brake is OFF before remote start.
- Hood is closed.
- Hand brake / neutral safety is satisfied.
- Vehicle is in Park or Neutral.
- Doors are closed.
- No person is working near the engine bay.

### **WARNING**

Never enable remote start on an unsafe manual-transmission installation. Additional safety logic is required.

## TROUBLESHOOTING GUIDE (1)

Symptom	Possible Cause	Solution
No power to system	Red/Black wire	Check fuse and ground
Push button not working	Brown/Black found	Check button connector and ground
Engine does not start	IGN/START wrong	Check ignition circuits
Remote not working	Remote battery dead or not programmed	Replace battery / program remote
Door not lock/unlock	Wrong wiring or sensitivity too high	Check door lock wiring

## TROUBLESHOOTING GUIDE (2)

Symptom	Possible Cause	Solution
PKE range too short	Antenna near metal	Reposition antenna
Auto lock/unlock not working	DIP switch setting incorrect	Check DIP OFF/ON setting
Remote start fails	Brake input not connected	Check brake wire
Car alarm keeps triggering	Shock sensor sensitivity too high	Adjust sensitivity or reposition



Remote battery: CR2032

# SPECIFICATIONS

Item	Specification
Operating Voltage	DC 12V +/- 3V
Static Current	< 25mA
Remote Frequency	433.92 MHz
Remote Battery	CR2032
Working Temperature	-40C to +85C
Maximum Current	20A per output
Remote Range	>1500 ft open area (model dependent)

## Revision Note

Specifications may vary depending on production batch and vehicle installation environment. Verify the product label and included harness.

Thank you for choosing EFHIPS.

We provide limited warranty from the date of purchase.

[www.efhips.com](http://www.efhips.com)

[support@efhips.com](mailto:support@efhips.com)

QR Code Area

**Thank you!**

© EFHIPS. All rights reserved.